

Inductive Loop Vehicle Detectors

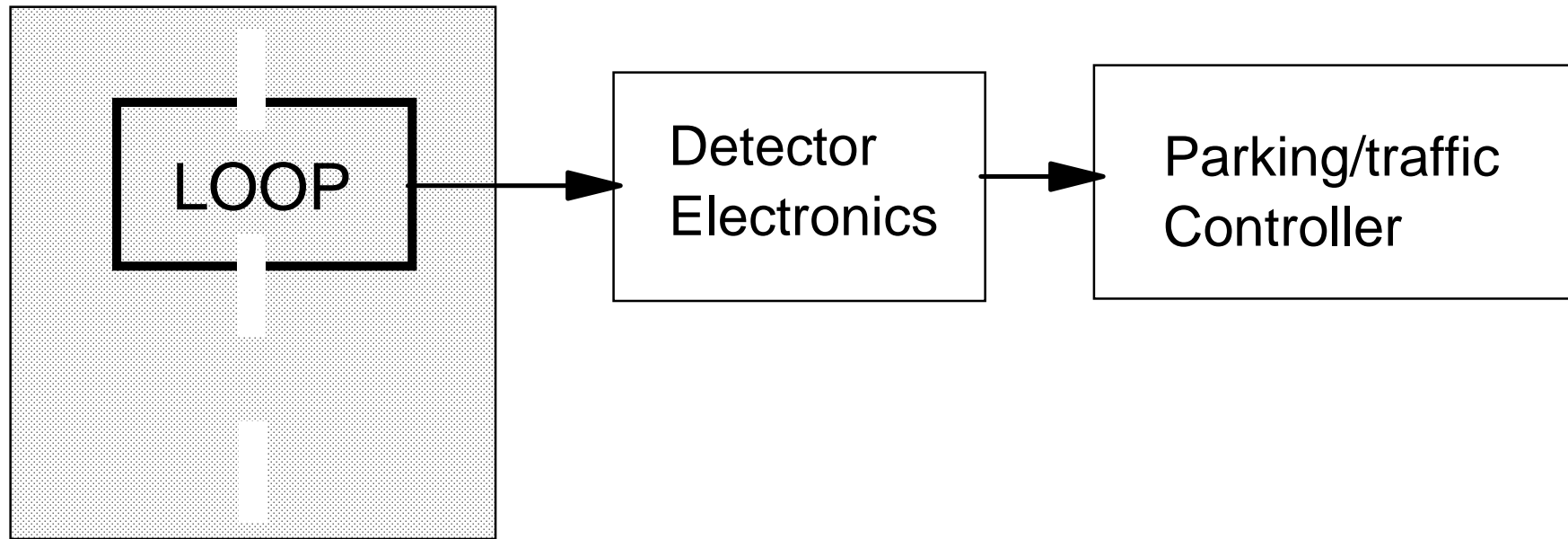

A simple loop detection system is made up of three elements.

- * Inductive loop, this simply consists of a coil of cable buried under the surface of the road.
- * Detector electronics - connected to the electronics by means of a feeder cable.
Detects the presence of a vehicle over the loop and in turn provides an output.
- * Controller, that is usually used for parking, traffic, or industrial door/gate applications.

Theory Of Operation

UNOCCUPIED LOOP

- Detector tunes to loop
- Loop energizes at natural resonant frequency (20 -150KHz)
- Magnetic flux surrounds Loop conductors.

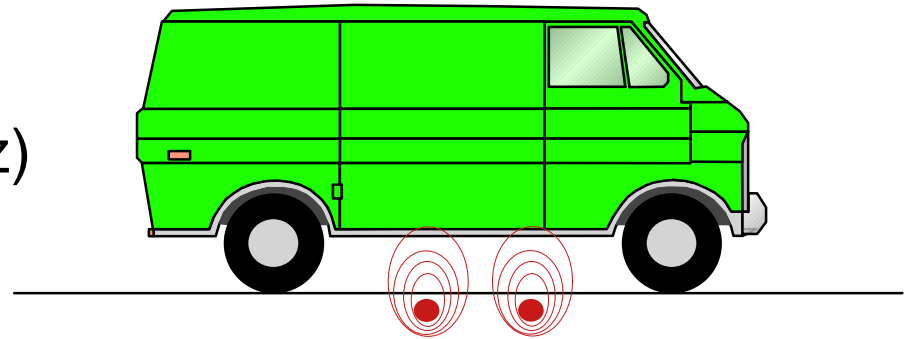

OCCUPIED LOOP

- Ferromagnetic effect - loop inductance increases
- Eddy currents - loop inductance decreases
- Ferromagnetic effect swamped by eddy currents

Theory Of Operation

An inductive loop is a coil of insulated conductor with a specific geometry that is energised by a low voltage signal from the detector electronics. A resulting magnetic field will surround the cores of this loop.

When power is applied to a vehicle detector connected to a loop, the electronics will automatically tune to that loop.

The loop oscillates at the natural resonant frequency, of the specific loop, to which the electronics are connected. Frequency is directly influenced, by capacitance in the detector electronics and inductance, which exists in both the loop and electronic components. Generally detectors will operate in the range of 20 to 150 kHz. It is usual for Nortech parking detectors to operate at even lower frequencies between 15 and 80kHz.

The effect of this oscillation is a magnetic flux that surrounds the loop conductors in the roadway. This is illustrated in the diagram.

When a vehicle moves over the loop and cuts into this magnetic flux two influences will result.

The ferromagnetic material usually located in steel belt tires and smaller engine components cause a transformer action and increases loop inductance. This is known as the ferromagnetic effect.

The eddy current effect, caused by the greater part of the vehicles chassis and body opposes the magnetic field and thus results in a decrease loop inductance.

The eddy current effect generally supercedes the ferromagnetic effect with a consequent overall decrease in loop inductance.

Inductance and frequency are inversely proportional therefore with the decrease in loop inductance we have a resultant increase in frequency. It thus follows that by analyzing the positive change in frequency the vehicle detector is able to sense the presence of a vehicle over a loop.

Typical Inductance Changes

<u>VEHICLE</u>	<u>dL/L</u>
MOTORBIKE	0.12%
ARTICULATED TRUCK	0.38%
FOUR WHEEL DRIVE	0.40%
5 TON TIPPER TRUCK	0.45%
MOTORCAR	>1.00%
FORKLIFT	>1.00%

LOOP: 2m x 1m (3 turns)

A vehicle will cause an inductance change when moving over a loop.

This table shows the typical inductance change over a 2m by 1m loop, caused by different vehicle types under ideal conditions. This loop size is characteristic in most parking installations.

Inductance change is shown by $\Delta L/L$ (Delta L over L) which symbolizes the percentage change in inductance relative to the inductance with no vehicle present. This percentage reflects the decrease in inductance against the total inductance of the system.

A vehicle not shown on this table but is worth mentioning, is a bicycle, which causes a very small inductance change of 0.02%, equivalent to the maximum sensitivity setting of Nortech detectors.

Inductance changes over a loop can be effectively measured using the DU100 diagnostic unit.

Loop Geometry

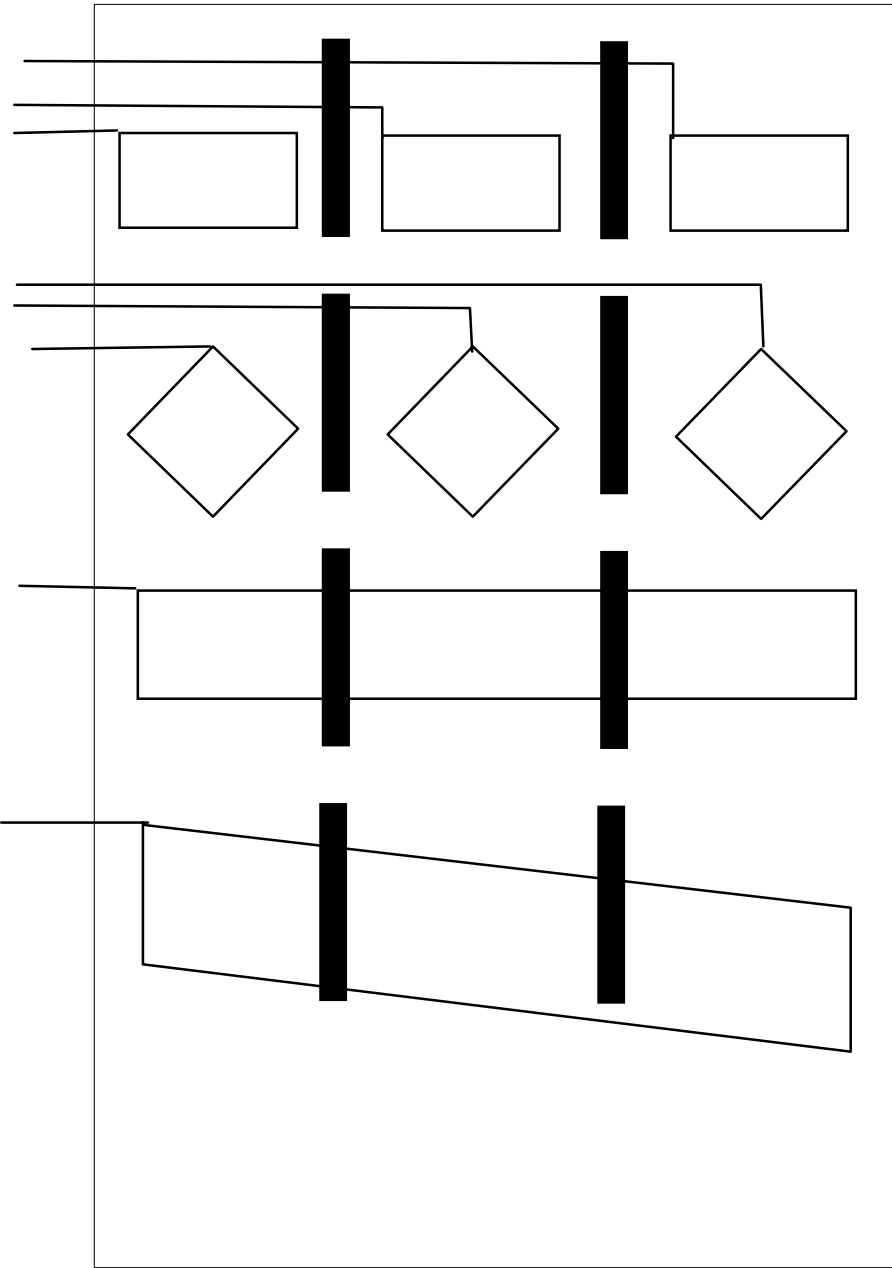

INDIVIDUAL RECTANGULAR

INDIVIDUAL DIAMOND

MULTI-LANE RECTANGULAR

MULTI-LANE ANGLED

Loop Geometry

Ongoing debates have taken place as to which loop geometry is the ideal. Most configurations are sufficient but some do possess definite benefits over others. The application normally determines the best loop configuration. We would like to outline some of the most common geometries in use today.

The conventional, individual rectangular geometry is the most effective loop for most applications and as such is the most commonly used.

Where smaller vehicles, such as bicycles, need to be effectively detected. Use is often made of loops that are angled to the direction of traffic flow, ensuring smaller vehicles cut a larger area of the magnetic flux as the field is perpendicular to the cable. The individual diamond configuration is a good example of this. This geometry is most commonly found in traffic intersection applications where all vehicle types need to be detected.

Multi-lane rectangular and multi-lane-angled geometries are simply variations of the previous two configurations, that span more than one lane.

Although the various configurations have their own unique benefits, where possible it is recommended that the Individual lane rather than Multi-lane geometries be used.

Individual loops are more sensitive as a larger area of the loop is covered and therefore a greater change in inductance occurs. Increased flexibility is introduced in the ability to monitor each in individual lane.

Bi-directional Loop Specification

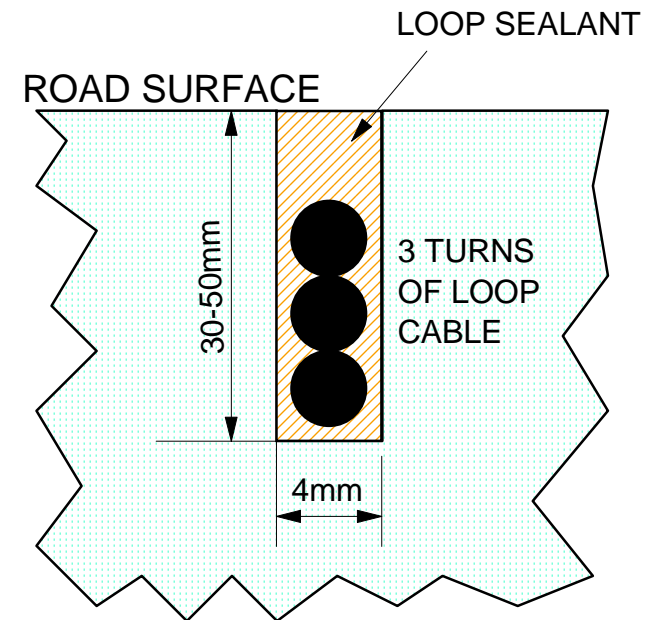
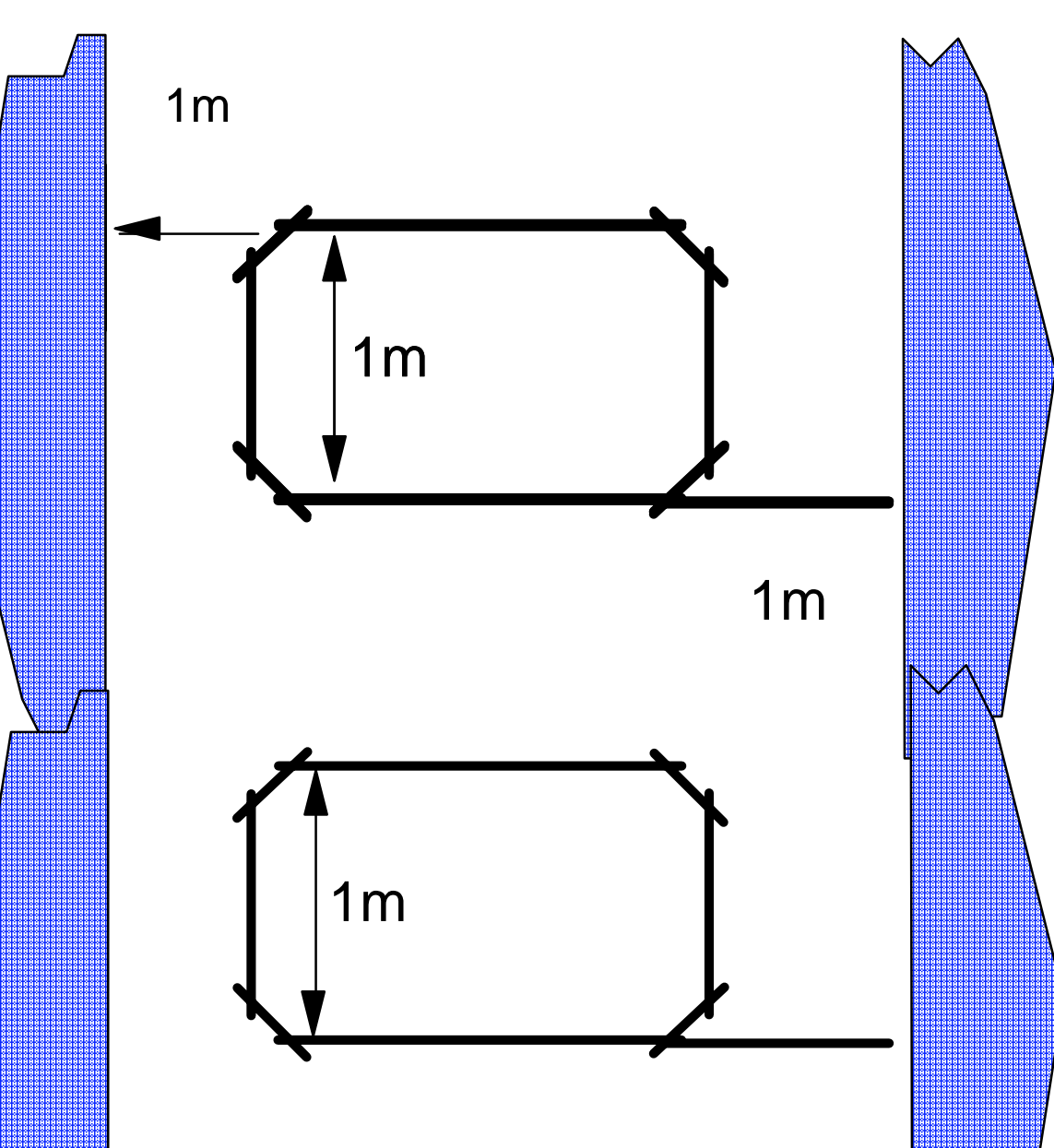

Loop Installation

Once a loop geometry has been decided for a specific application. The loop should be marked out on the roadway using chalk. The length of the loop will be determined by the width of the road, and needs to extend to within 300mm of the edge of the roadway ensuring vehicles will always pass over the loop.

The next step would be the cutting of the loop slot. This is normally carried out using an angle grinder with a masonry disc, diamond blade or similar device. The depth of the slot will be determined by the number of turns of cable required in the loop and will vary between 30 and 50 millimeters.

90-degree angles present sharp edges that can easily damage cable insulation with road movement and lead to loop failure. It is therefore important to remember 45-degree crosscuts when cutting slots. These provide for important stress relief and improve the longevity of the loop.

All debris should be removed from the slot once cutting is complete and prior to laying cable, thus ensuring no sharp objects remain to damage the cable.

Loop Installation

The next step would be the laying of cable in the loop slot. The cable should be lead from the electronics to the loop slot, laid around the slot with the number of turns required and then led via the exit point back to the electronics. Where possible the loop and feeder combination should always consist of a single non-joined length of cable. Where this is not possible use must be made of a waterproof junction box, and the joints must be soldered the feeder cable should be twisted from the point of exit from the loop through to the electronics. It is important when measuring the cable from the detector to the slot to allow for cable length shrinkage caused by feeder cable twisting.

Once the cable has been laid and the installation tested the slot is sealed using hot pour bitumen mastic, an epoxy compound or commercial loop sealant. Materials without waterproofing properties, are not acceptable substitutes for slot sealing. It is vital to ensure the slot is well packed with the sealant to prevent water ingress.

The DU100 diagnostic unit can be used to test the loop prior to sealing to ensure sufficient turns and operating inductance.

Loop Parameters

<u>PERIMETER SIZE</u>	<u>No. OF TURNS</u>
3 - 6m	4
6 - 10m	3
10 - 30m	2

MATERIAL:

Silicon insulated

Copper conductor (1.5mm²)

The rule of thumb, for the number turns needed for loop are shown in this table. The greater the total perimeter of the loop, the fewer number of turns required. When it is apparent that reinforcing or any other ferrous material is in close proximity to the loop an additional two turns should be added to the number specified. It is important to note that one should never have less than two turns per slot as this will severely affect operation.

Cable for loop installations should constitute a multi-strand, PVC or silicon insulated copper conductor, with a minimum 1.5mm squared cross sectional area. A conductor with a cross sectional area of less than 1.5 millimeters squared is not suitable and could severely decrease the effectiveness of the installation. When possible, silicon insulation should be chosen as it contains better properties than PVC insulation.

Loop - Typical Values

Loop Inductance is a function of:

➤ Loop geometry and No. of turns

* 1 turn is approx 1.5 uH/m

* 3 turns is approx 9.3 uH/m

➤ Feeder Length

* 0.6 uH/m

Loop inductance is a function of loop geometry and feeder length.

A single turn on a loop will give a measured value of 1.5 micro-henries per meter, this value will increase to 9.3 micro-henries per meter with three turns on a loop.

A twisted pair feeder cable running from the loop to the electronics will yield 0.6 micro henries per meter.

When planning a loop layout it is important to maintain a minimum 4 to 1 ratio between the loop and feeder combination. Feeder cables should therefore as a rule be kept as short as possible. The higher a feeders inductance the less sensitive a loop will become.

Proximity Of Ferrous Metal

Causes

- Re-enforcing under road surface
- Man hole covers
- Buried Tram Lines

Effects

- Reduced sensitivity
- Cross-talk between Loops
- Possible system failure

Proximity Of Ferrous Metal

We have touched briefly on the proximity of ferrous metals around a loop. The normal causes are steel reinforcing below the surface of the road and the more visible manhole covers.

Effects of the proximity of ferrous metals to the loop are reduced sensitivity and possible system malfunction. This can invariably be overcome by the addition of two turns of cable to the loop, thus compensating for the reduced sensitivity.

Manhole covers and similar objects are usually visible and should be avoided, where possible with a minimum margin of 1 meter. Where it is known that steel reinforcing exists an effort should be made to, where possible, install the loop at least 50 millimeters above the metalwork, or as near to the surface as possible.

In severe cases, a low hump may be required over the loop allowing the loop to be installed near the surface.

Where reinforcing is present the possibility exists that frequency can be transferred across this reinforcing and interfere with a loop, having a similar frequency, a number of lanes away.

Although not common this can usually be easily solved by shifting the frequencies of the two loops using the detectors frequency switches.

In multi-lane installations, it is good practice to alternate the number of turns in adjacent lanes to ensure a greater number of frequency combinations.

This is not necessary where adjacent loops are connected to a multi-channel detector.

Feeder Cable

- Length - 150m max
- Cross-sectional area - 1.5mm²
- Twisting - greater than 20 turns per metre
- Shielding - earth one end only
- On shorter runs the tails of the Loop may be used

Feeder Cable

An important part in ensuring a successful loop installation is following certain guidelines for feeder cables.

The maximum length of a feeder in a traffic installation is 150m. When considering feeder length one should always remember that a 4 to 1 ratio is required between loop and feeder inductance.

The conductor requirements for the feeder are the same as those for the loop, a minimum rating of 1.5mm squared cross sectional area.

The feeder should always be a twisted pair and it is important that the twisting is maintained from the loop to the electronics terminal.

Twisting of the feeder ensures a stable feeder inductance and reduced interference, from electrical noise and adjacent loop feeders and cables. The minimum requirement is 20 twists per meter.

Feeders can be easily twisted by securing the ends in the chuck of a hand drill. It is recommended that the twisted pair be fastened to prevent unraveling whilst feeding through conduits.

In electrically noisy environments the twisted feeder pair should be shielded and earthed on the electronics end only.

Detector Electronics

- Stable frequency source
- Intelligent tuning algorithm
- Microprocessor based frequency measurement
- Integral Loop analyser/compensator
- Digital filtering
- Environmental protection

Detector Electronics

Due to environmental and other external influences that may effect the performance of a loop system a number of key elements need to be incorporated into the design of a modern vehicle detector.

A stable frequency source is required to prevent false detects this is ensured through the use of high quality components, strict manufacturing practices and quality control.

An intelligent tuning algorithm is important to ensure a detector has the ability to tune to a broad inductance range, thus allowing for the use of a wide variety of loop configurations.

Microprocessor technology allows for the accurate digital analyzing of frequency to determine the precise level of loop inductance.

The change of inductance is inversely proportional to the change in frequency and vice versa.

An integral, digital loop analyzer, constantly analyses frequency changes caused by external influences on the system and compensates for these changes to ensure a stable installation.

Digital filtering allows accurate outputs in response tracking the profile of a vehicle over the loop.

Electronics are susceptible to induced voltage spikes and as such need sufficient protection from the environment.

No compromise is to be made on environmental protection, this includes safety from both the loop and the power supply.

Temperature Effects

- Operating range (-20 to +70 centigrade)
- Drift
- Compensation (2 degrees C per minute)
- Retune Window

Temperature is one of the primary environmental influences that could effect a loops performance. Nortech have therefore incorporated sophisticated algorithmic features in their detectors to counteract these effects.

Vehicle detectors should operate over a wide temperature range. Nortech detectors are tested between -40 degrees centigrade and +80 degrees centigrade.

Temperature does have an effect on the resonance of a loop and the installation. Drift is the term used to describe the change in frequency over a period of time relative to the original frequency reference on tuning the detector. It is important to note that drift in a detector installation should never be greater than 3%. Use can be made of the DU100 diagnostic unit to monitor drift.

Nortech detectors monitor the change in temperature and compensate for these changes up to 2 degrees centigrade per minute. If the drift rate exceeds the limits of operation the detector will automatically retune.

Detector Output

- Parking Detectors (Relay) Traffic (Relay/Solid State)
- Presence/Pulse output
- Fault output
- Fail safe / Fail Secure

The majority of demand remains for relay outputs. Nortech Parking detectors have two relays. A presence relay, which provides an output for the duration of the vehicles presence over the loop, and a pulse relay which provides an output of fixed duration. The standard pulse output is a 150 millisecond duration, with a 250 millisecond factory option. The pulse relay can be selected to provide a pulse as the vehicle enters the loop or as the vehicle exits the loop.

A more common alternative in traffic applications is the solid state output. These take the form of opto-couplers and open collector transistor outputs. Also more common to traffic detectors is the fault output, this is initiated in the event of a open or short circuit on any of the loops connected to the module.

The majority of Nortech's presence relay outputs are fail safe, which means that the relays are energized and will de-energize on a detect. If a power failure or loop fault occurs the system will maintain the status as if there is a vehicle present on the loop.

A fail secure factory option is also available. With this option the detector will assume there is no vehicle present over the loop in the event of a power failure.

Detector Presence Time

- Loop drift is limiting factor
- Optimized as non-linear function of inductance change
- Permanent presence

Presence time can be defined as the period that an output is maintained while a vehicle is present over the loop.

Presence time is limited by a software function.

In limited presence mode, a vehicle will be detected when moving over a loop. Should that vehicle remain on the loop, over a period of time algorithmic trending will cause the detector to drop out of detect. This period is approximately 3 hours for a 1 % delta L/L change.

The smaller an inductance change caused by a vehicle over a loop, the shorter the presence time and vice versa. Limited presence time is determined by the level of inductance change and is therefore said to be optimised as a non-linear function of inductance change.

It is often necessary that a vehicle needs to be detected for an infinite period. Modern microprocessor detectors offer a permanent presence option. In this mode the detector will monitor environmental changes and track them ensuring that the vehicle remains detected for its entire presence over the loop.

Detector Sensitivity

- Minimum change in inductance required to cause a detect
- Typically 0.02% dL/L
- Larger Loops have less sensitivity

Detector sensitivity can be explained as the minimum change in inductance necessary to cause a vehicle detect.

Nortech vehicle detectors require a minimum of 0.02 change in inductance relative to the initial reference to cause a detect. This will be the maximum sensitivity setting and should be sufficient to detect a bicycle.

As mentioned earlier in the presentation it is important to remember that a larger loop will be less sensitive than a smaller loop. It therefore follows that should smaller vehicles such as bicycles need to be detected, it would be preferable to use an individual rather than a multi-lane loop. The size of a loop should however never be smaller than 500mm x 500mm.

Crosstalk

CAUSES:

- Electromagnetic coupling
- Mutual Coupling

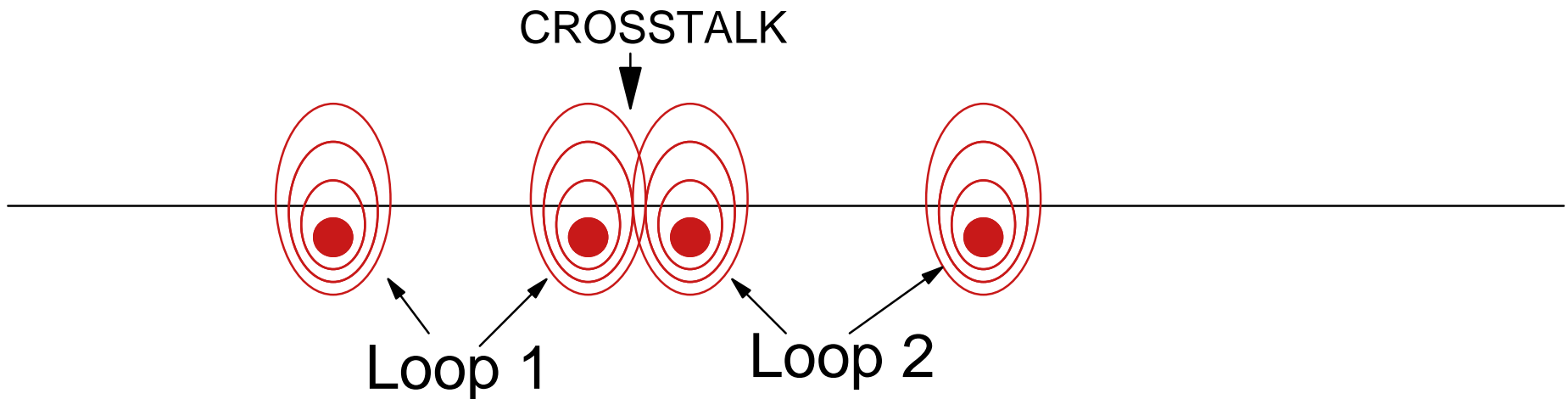

One of the most common and perhaps misunderstood occurrences in vehicle detection is crosstalk.

This usually occurs when two loops connected to different detector modules are in close proximity to one another. The magnetic fields surrounding the loops interfere with each other. This is a result of either mutual or electromagnetic coupling.

Crosstalk

Effects:

- Erratic detects
- Lockup
- Retune/Reset

Remedies:

- Multiplexing
- Frequency offset
- Twisting
- Shielding

Erratic detects where a vehicle detected on one loop will be transferred to the other. Detector crosstalk is when detectors detect and un-detect in rapid succession. The most common physical evidence of crosstalk is when relays chatter and the LED's flash on and off at the same rate.

Lockup is when a detector enters a mode, resulting from the interference, where it assumes a vehicle is present over the loop.

The simplest method of eliminating crosstalk is to allow sufficient spacing between the two loops.

The detectors may also automatically reset frequently and at random.

The minimum spacing between two loops connected to different modules should be 2 meters. This however is not always possible and therefore a number of other methods can be used to counteract crosstalk, these include;

Use of dual channel detectors where loops are rapidly multiplexed thus effectively eliminating any possibility of crosstalk as loops are never energized at the same time. This also allows for loops to be in close proximity and even share a common slot.

Interference occurs when the frequencies of two loops are similar. Frequency switches on the detectors can be used to shift the frequencies of the two loops further apart. This is known as frequency offset.

Twisting loop feeders minimises the effects of interference and should be maintained all the way to the detector electronics as crosstalk will also occur in feeders and in the cabinet.

Shielding can also aid in the elimination of crosstalk.

Special Modes

- Direction logic (AB logic)
- Speed logic
- Headway count
- Delay / extend logic

Special modes available as an integral part of the various multi channel vehicle detector models include:

AB or direction logic, which is able to determine vehicle direction, as it travels over two loops. It is interesting to note that Nortech was the first company to make this logic available in a detector rather than a separate logic unit.

Speed logic is able to determine the speed of a vehicle as it traverses two loops. Headway logic determines the following distance of a vehicle

Delay/extend logic will either prolong an output, as a vehicle leaves the loop or delay the initiation of an output when a vehicle moves onto a loop.

Commissioning

Loop:

- Insulation resistance ($>50\text{Meg Ohm}$)
- Series resistance ($<10\text{ Ohm}$)

Detector settings:

- Frequency
- Sensitivity
- Special modes/features

Commissioning

Once a loop has been installed, the detector commissioning can follow.

It is advisable to test the loop at this stage specifically where contractors have been used to install loops.

It is recommended to check insulation resistance by taking a mega reading of the loop, to ensure no inherent problems. A mega is a device that measures the loop insulation resistance by placing a very high voltage at its probes, typically 500 to 2500 volts. The ideal would be an infinite value, this is however not practically possible and the reading should be as high as possible. A reading around 50 to 100 megs would indicate a good installation.

The DU100 diagnostic unit together with a detector could also be used to check for open or short circuits.

The series resistance should also be measured this should be taken at the feeder end to ensure both loop and feeder are tested. A high resistance loop will affect the 0 of the loop and this can result in problems. The resistance of the loop should be lower than 8 ohms however a reading of 3ohms or less would be ideal.

The availability of the DU100 diagnostics unit today, allows for effective checking of selectable items during commissioning. Short and open circuit loops can be identified.

Commissioning

The availability of the DU100 diagnostics unit today, allows for effective checking of selectable items during commissioning. Short and open circuit loops can be identified.

Frequency can be determined. In multi loop installations a test will show a potential crosstalk situation and necessary frequency separations can be made to pre-empt any problems.

Loop sensitivity levels can be checked, through the availability of absolute maximum and minimum inductance changes caused by vehicles over the loop.

It is a good idea to check loop drift a few days after commissioning to ensure no unnecessary maintenance callouts later.